

# M40



## AAKCCB48系列說明書 AAKCCB48 INSTRUCTION MANUAL

**KWC** KIEN WELL TOY INDUSTRIAL CO., LTD  
www.kwcgun.com

台南市仁德區義林路168巷89號  
NO.89, LN. 168, YILIN RD.,  
RENDE DIST., TAINAN CITY  
71752, TAIWAN (R.O.C.)  
TEL : +886-6-2798175  
FAX : +886-6-2798176  
sales@kwcgun.com  
www.kwcgun.com



## 操作/OPERATION

### 操作說明 OPERATION

#### 1. 取出彈匣 RELEASE MAGAZINE



1. 按下卡榫  
Press the button.
2. 取出彈匣  
Release the magazine.

▲注意:請勿使彈匣直接掉落地面,以防止變形或損壞。

▲CAUTION: Magazine falling directly on the ground could cause deform or damage on it. Please be aware.

#### 2. CO2小鋼瓶12g的使用 INSTALLING 12G CO2 CARTRIDGE

逆時針轉出彈匣底內件後,置入小鋼瓶B,再以順時針方向鎖緊彈匣底內件A。當刺破鋼瓶出氣時,請快速鎖緊。

Turn the magazine cap out counter-clockwise and place CO2 cartridge B inside the magazine. Rapidly turn the screw A clockwise when piercing the cartridge in the magazine.

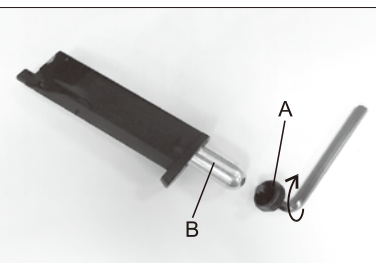

▲注意:為維護彈匣使用壽命,請盡可能不要殘留CO2氣體於彈匣內。

▲CAUTION: To protect your magazine, please release all of the CO2 out of the magazine after every use.

#### 3. 填裝B.B彈 LOADING BBs

彈匣最多可裝15顆B.B彈,如強行裝入更多,可能造成不當損壞及無法上膛,請注意。

BB's max capacity is 15 rounds. If you load more than this quantity, you would bring any abnormal problems.

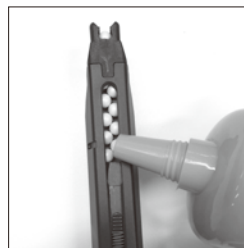

▲注意:裝雙排彈時請確認排列整齊,若有少子彈排列,射擊會造成空發現象。

▲CAUTION: Please make sure BB loading one by one for smooth shooting. If loading BB casually, it may cause the dry firing.

#### 4. 彈匣上膛 INSERTING THE MAGAZINE

將裝好B.B彈的彈匣插入槍身上推入,直到彈匣卡榫發出"卡嗒"為止。Insert fully loaded magazine in the airsoft until you hear the sound of "CLICK".

#### 5. B.B彈上膛 CHAMBERING THE BB

將上蓋往後拉到底,放開上蓋則會自動回位,同時亦將B.B彈送上膛完成射擊準備。Pull the slide all the way back, then release the slide to cock the pistol.



▲注意:拉動上蓋時,請勿將手指扣住扳機,以免發生不當射擊,造成危險。

▲CAUTION: The gun is now cocked and will fire when the trigger is pulled. Be careful not to fire accidentally.

#### 6. 保險切換 SWITCH SAFETY



▲注意:上蓋滑動時,注意縫隙夾到手。

▲CAUTION: This airsoft has a realistic blowback feature. Be careful of the pinch point.

#### 7. 射擊 SHOOTING

對準目標區後扣下扳機,則B.B彈將被射擊出去。Aim the target and pull the trigger. Then the BB will be shot.



▲注意: B.B彈用完時,上蓋會後定卡住。

▲CAUTION: hold open function as real pistol.

## 拆解/DIS-ASSEMBLY

#### 1. 按下卡榫,取出彈匣。 Press the magazine catcher to release the magazine

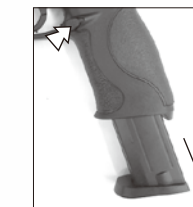

#### 2. 導管卡榫往下,上蓋往後拉。 Push down slide catch and pull slide back.



#### 3. 上蓋組件往左滑就可分離本體與上蓋。 Push slide to the left to disassemble frame and slide.



#### 4. 裝回時請先將上蓋滑入,必需到槍尾端後再按壓住槍管,這樣才能把導管卡榫往上扳回定位。 To assemble, put slide back and push the barrel as shown in the picture. Then push the slide catch up to lock the slide.



## 故障/BREAK DOWN

#### 5. HOP UP 調整。 adjust HOP UP system.

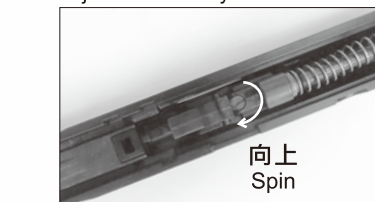

## 替換槍柄/ GRIP EXCHANGE

#### 1. 將握把固定件向右旋轉90度。 Turn grip guide to right side 90 degree.

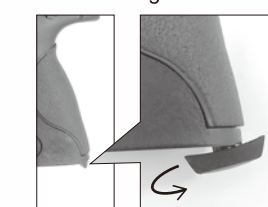

#### 2. 即可拉下握把固定件。 Pull out the grip guide.

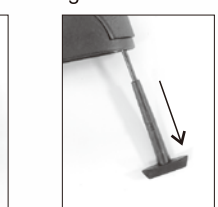

#### 3. 槍柄握把向右拆除,以利替換其他握柄。 Take out the grip and change to other type.

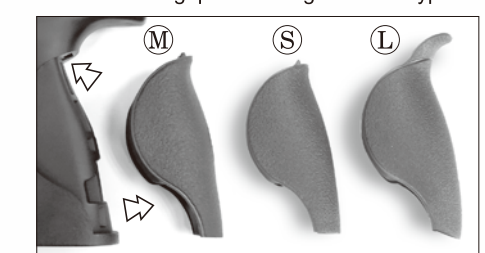

## 故障的原因與排除 BREAK DOWN FAQ

\* 卡彈可能原因:  
the reason for BB jam :

- a. 裝彈排列不整齊  
the BB in the magazine does not arrange very well.
- b. 不良B.B彈  
bad quality BB

c. 空擊發易造成零件損耗,請避免此動作。  
Please avoid dry firing, for it could cause parts deformed or damage.



\* 排除:將上蓋往後拉,向下倒出即可。  
Solution: pull the slide back and pour the BB out from slide.



## 保養及維護 MAINTENANCE GUIDE

當射擊約2000發時,建議你如圖所示,以矽油脂適當在上蓋與本體滑動接觸面及擊鐵、撞針作動處潤滑,以利滑動。  
After every 2,000 BB shots, lubricating the Firing pin and Track as pictures below is recommended.

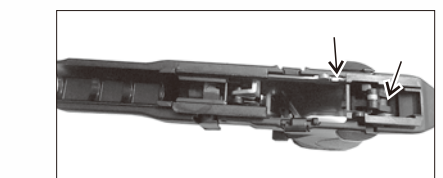
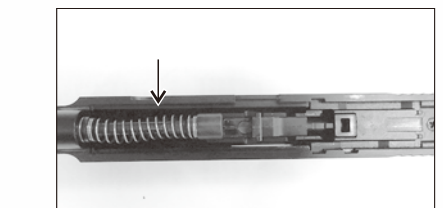



# WARNING 警告

## 請務必嚴格遵守 使用說明指導書

For your safety, please read this manual carefully before use.

此低動能遊戲用槍是針對喜愛射擊運動的消費者所開發。避免因使用方法不正確或改造所發生的故障或事故，請務必詳讀說明書，正確的操作享受愉快的射擊運動。

- 除了發射時外，不要將手指頭掛在板機上。
- 選擇安全與適當標靶
- 在非使用期間，請保持保險關閉且退彈的狀態，就算在非使用狀態，也要如同其已裝彈。
- 如任何的機械產品，槍的保險也可能失效。即使在保險關閉的狀態下也請小心的操作此槍，請勿將槍口對人。
- 千萬不要對堅硬或平坦表面、水面射擊，以避免跳彈。
- 請妥善保管產品在未未成年孩童無法伸手取得的場所。
- 每次使用前後都應該檢查擋彈物，假如擋彈物表面有磨損失效或是反彈時請停止使用。
- 請使用高品質BB彈，請勿使用①口徑大於6mm②表面不平滑的③重複使用過的BB彈④非本說明書指名的發射物。
- 最高的使用及儲藏CO2小鋼瓶環境為50°C(122°F)以內，高溫可能會造成CO2小鋼瓶過熱甚至爆炸。
- 檢查任何掉落之槍枝，以確保未影響其功能。

**This airsoft is intended for recreational or training purposes. To prevent improper handling, modification or alteration causing malfunction or accident, please read the owner's manual carefully. Enjoy the pleasant shooting experience by proper operation.**

- Do not put your finger on the trigger except shooting.
- Please choose safe and proper target.
- Please always keep the airsoft on safe and unloaded when not using.
- Like all mechanical devices, an airsoft safety can fail. Always handle the airsoft safely even when the safety is "on safe". Never point the airsoft at any people.
- Avoid ricochet. Never shoot at a hard or flat surface or at water.
- Keep the airsoft out of reach for small children.
- Your backstop should be inspected for wear before and after each use. Discontinue use of the backstop if surface shows signs of failure or ricochet.
- Only use high quality BB. Never use ①BB diameter larger than 6mm②BB with unsmoothed surface③reused BB that has been fired④incorrect projectiles not design for this airsoft
- Do not expose CO2 cartridges to heat or store them at temperatures above 50°C(122°F). CO2 cartridges may over heat or explode at temperatures above 50°C(122°F).
- Check any gun that has been dropped to ensure that its function has not been affected.

★使用低動能遊戲用槍前，請務必戴上保護眼鏡或面罩。  
★Always wear eye protection when using airsoft.

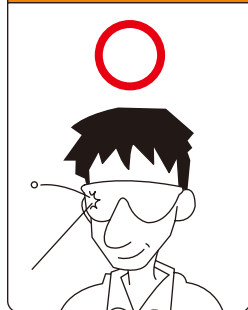

★使用低動能遊戲用槍前，請務必詳讀說明書內容。  
★Read the owner's manual before using the airsoft.

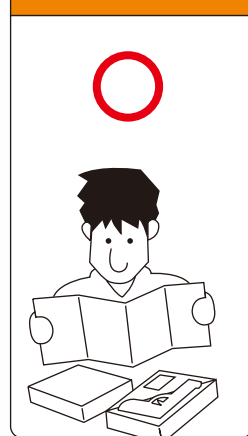

★不可攜帶低動能遊戲用槍在公共場所行走，請務必裝在袋子或盒子內。  
★Always transport an airsoft in a locked carrying case. Make sure it is unloaded and on safe.

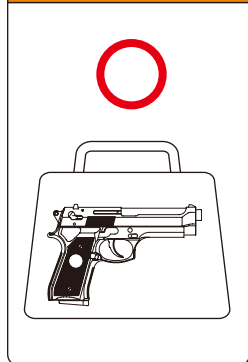

★請不要由槍口向內探視。  
★To Avoid accidental discharge, do not look directly into the barrel.



★請不要在公開場合使用低動能遊戲用槍，也請不要拿低動能遊戲用槍對準人或動物。  
★Never brandish or aiming this airsoft at any people or domestic animals. Brandish this airsoft in public is dangerous and may be a crime.

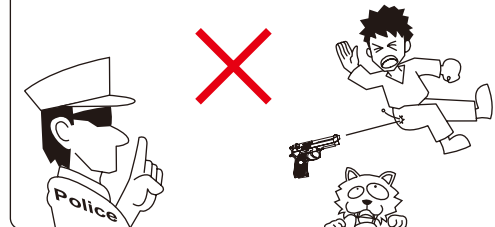

★請確認後再發射BB彈方向，附近無人或動物存在。  
★Always be aware of your surrounding before and during shooting and select a safe area for target practice.

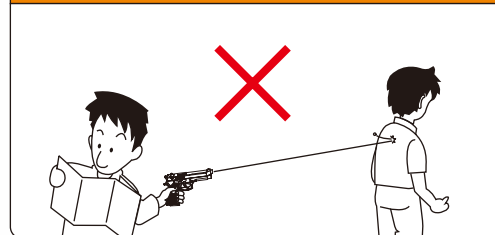

★不可任意改造或加工低動能遊戲用槍，私自改造加工會造成產品損壞、保固失效，導致使用上不安全，甚至觸法送辦。  
★Disassemble, modify, or alter of your airsoft may cause malfunction, void your warranty and may make it unsafe to use.

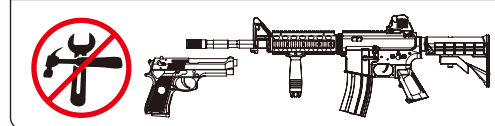

Do not display this pistol in public—it may confuse people and may be a crime. 請不要忘了，雖然自己知道這只是玩具，但不知道的人，會以為這是真槍。

# AAKCCB48 系列 零件表 AAKCCB48 SERIES PARTS LIST

NO.	零件名稱	UNIT	NO.	零件名稱	UNIT	NO.	零件名稱	UNIT
P01	本體	FRAME	Z22	保險(右)	SAFETY (R)	S03	扳機扭簧	TRIGGER SPRING
P02	扳機	TRIGGER	Z23	保險(左)	SAFETY (L)	S04	上蓋止動件扭簧	SLIDE STOP SPRING
P03	扳機連結件	TRIGGER CONNECTOR	Z24	彈匣滑粒	MAGAZINE FOLLOWER	S05	彈匣卡榫扭簧	MAGAZINE CATCH SPRING
P04	滑套射嘴	LOADING NOZZLE	Z28	鋼瓶鎖零件	MAGAZINE BOTTOM CAP	S06	導管卡榫扭簧	BARREL GUIDE CATCH SPRING
P05	氣流控制件	FLOATING VALVE	F01	上蓋止動件	SLIDE STOP	S07	回位導桿壓簧	RECOIL SPRING
P07	回位導桿前配件	RECOIL GUIDE FRONT GASKET	F02	子彈迫緊調整件	HOP UP ADJUST	S08	射嘴回位壓簧	LOADING NOZZLE RECOIL SPRING
P08	握把固定件	GRIP GUIDE	R01	氣嘴迫緊	GAS ROUTE PACKING	S09	氣流控制件壓簧	FLOATING VALVE SPRING
P09	彈匣上部	MAGAZINE RIB	R03	子彈迫緊	RUBBER CHAMBER	S10	彈匣壓簧	MAGAZINE SPRING
P10	彈匣底座配件	MAGAZINE BASE PLATE	R04	O形環S12.5	O-RING	S11	撞針拉簧	FIRING PIN SPRING
P11	彈匣卡榫	MAGAZINE CATCH	R05	O形環1X6	O-RING	S12	保險定位壓簧	SAFETY GUIDE SPRING
P13	槍柄(S)	GRIP (S)	R06	O形環 PU S-4	O-RING	S13	導桿回位緩衝壓簧	RECOIL BUFFER SPRING
P14	槍柄(M)	GRIP (M)	B01	內槍管	BARREL	S14	導管卡榫定位軸壓簧	BARREL CATCH GUIDE SPRING
P15	槍柄(L)	GRIP (L)	B03	槍身內套軸	TRIGGER CASE PIN	S15	撞針卡榫壓簧	FIRING PIN CATCH SPRING
P16	回位導桿墊圈	RECOIL GUIDE MIDDLE GASKET	B04	槍管接筒軸	OUTER BARREL PIN	S20	KG-15心棒壓簧	REAR VALVE SPRING
P41	心棒迫緊	VALVE PACKING	B05	扳機軸	TRIGGER PIN	E01	止付螺絲M2.5X6黑	SCREW
KG15-PO8	氣缸迫緊	CYLINDER PACKING	B06	彈匣上部軸(長)	MAGAZINE RIB PIN(L)	E02	Φ1.3X6束黑熟	SCREW
A01	上蓋	SLIDE	B07	擊鐵箱固定軸	CHASSIS PIN	E03	Φ1.3 M3X6黑	SCREW
A02	外槍管(大孔)	OUTER BARREL	B08	擊鐵卡榫軸	HAMMER CATCH PIN	E04	止付螺絲	SCREW
Z01	擊鐵箱	CHASSIS	B09	扳機配件軸	TRIGGER CONNECTOR PIN	E05	KA-01彈簧墊圈	SPRING WASHER
Z02	槍身內套	BARREL BASE	B11	子彈迫緊調整螺絲	HOP UP ADJUSTABLE SCREW	E06	2mm鋼珠	STEEL BALL
Z03	導管卡榫	SLIDE CATCH	B13	握把固定件軸	GRIP GUIDE PIN	E07	M2彈簧墊圈	SPRING WASHER
Z04	槍管定位件(左)	BARREL UNIT L	B14	擊鐵軸套軸	TRIGGER BAR CONNECTOR PIN	E08	M2螺母	NUT M2
Z05	槍管定位件(右)	BARREL UNIT R	B16	扳機連桿連接軸	TRIGGER BAR SLEEVE	E09	Φ3.0X8鍍銀/耐腐處理	SCREW
Z06	回位導桿	RECOIL SPRING GUIDE	B17	氣閥本體	VALVE FRAME			
Z07	扳機連桿	TRIGGER BAR	B18	心棒後部	REAR VALVE			
Z08	擊鐵	HAMMER	B19	擊鐵軸套	HAMMER SLEEVE	X1	內槍管組件	INNER BARREL UNIT
Z09	擊鐵卡榫	HAMMER CATCH	B21	槍管定位件軸	BARREL GUIDE PIN	X2	氣缸組件	CYLINDER UNIT
Z10	撞針	FIRING PIN	B22	射嘴壓簧導軸	NOZZLE SPRING GUIDE	U1	擊鐵組件	HAMMER UNIT
Z12	保險止動件	SAFETY STOP	B24	導管卡榫定位軸	SLIDE CATCH GUIDE PIN	U2	扳機連桿組件	TRIGGER BAR UNIT
Z14	撞針卡榫	FIRING PIN CATCH	B25	彈匣上部軸(短)	MAGAZINE RIB PIN(S)	U3	氣閥組件	VALVE SET
Z15	氣缸座	CYLINDER BASE	B26	氣瓶頂針	PUNCTURE VALVE	U4	氣瓶頂針組件	PUNCTURE VALVE UNIT
Z16	後準星	REAR SIGHT	B27	心棒	VALVE	U01	六角扳手	WRENCH
Z17	前準星	FRONT SIGHT	B215	氣瓶頂針迫緊	CARTRIDGE VALVE PACKING			
Z18	上蓋飾片	SLIDE SIGE COVER	S01	擊鐵扭簧	HAMMER SPRING			
Z21	彈匣本體	MAGAZINE FRAME	S02	擊鐵卡榫扭簧	HAMMER CATCH SPRING			

# AAKCCB48 系列 零件分解圖 AAKCCB48 SERIES EXPLODED VIEW

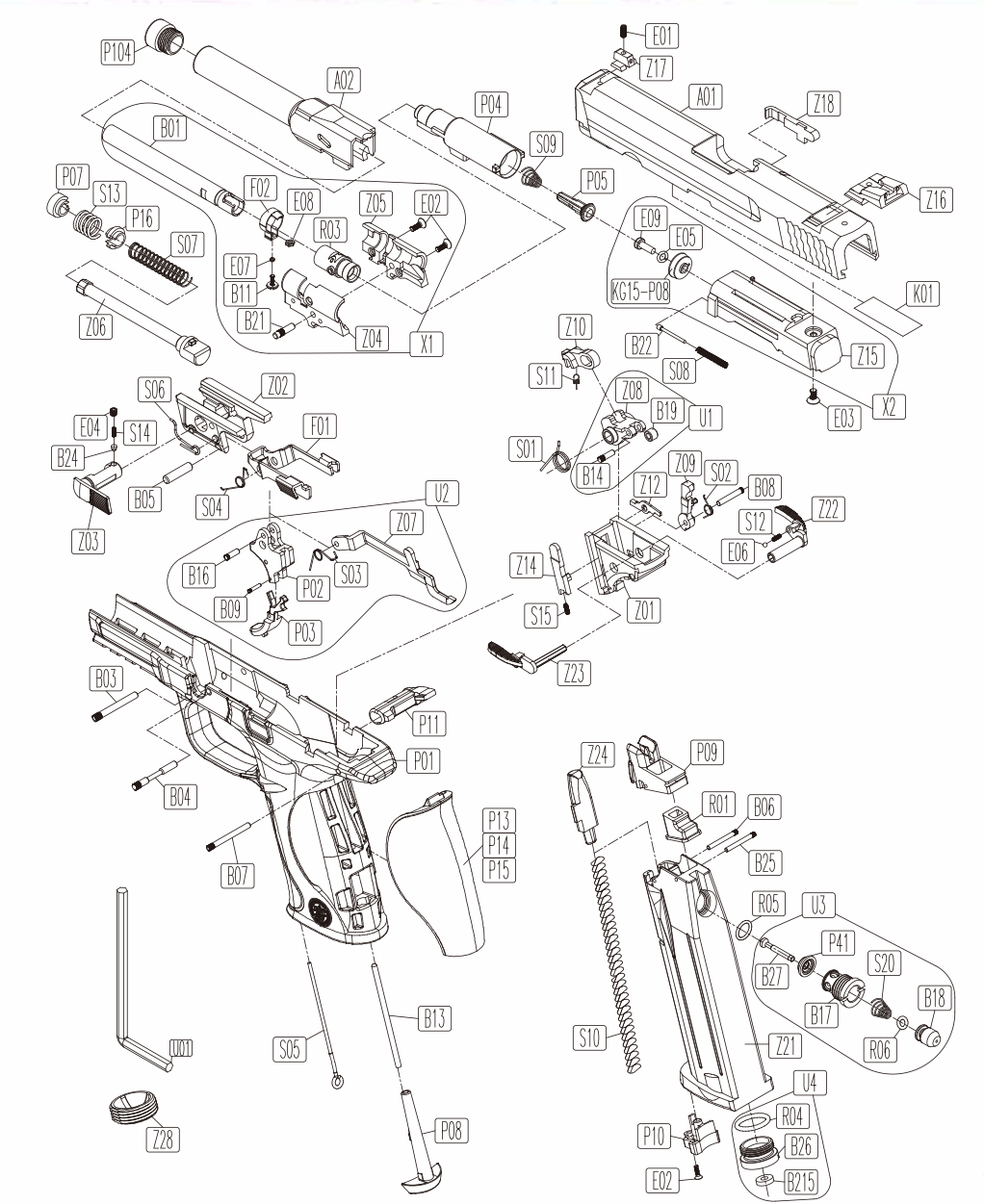

※零件有時為了改良而不經預告變更。  
Spare parts may be modified for quality improvement  
And such modification may be without advance notice.